



R'EVO

R'EVO

Lineare. Moderna. Essenziale. Ecco R'Evo,
la porta reversibile di Edilgreen,
caratterizzata dalla possibilità di
scegliere il senso di apertura
in fase di montaggio.

*Linear. Modern. This is R'Evo, the Edilgreen's reversible door,
characterized by the possibility to decide door's opening, while assembling.*





R'EVO

MATERIALI

Coprifili realizzati in LSB
(materiale tecnologico e resistente,
senza formaldeide).

Stipiti realizzati in listellare di abete

Cerniere MADE IN ITALY a scomparsa
regolabili in 3D e perno stabilizzatore

Serratura magnetica MADE IN ITALY

Guarnizione in espanso

MISURE DISPONIBILI

Pannello con spessore da 40 mm

BATTENTE:

700/750/800/900 x 2100 mm

SCORREVOLE:

700/800/900/1000 x 2100 mm

MATERIALI

Mouldings realized in LSB

*(a technological and resistant material
without formaldehyde)*

Jambs in fir tree's blockboard

*Hidden hinges "made in Italy" adjustable
in 3D and stabilizing linchpin*

"Made in Italy" magnetic lock

Foam seal

SIZES AVAIBLE

Panel of 40mm thickness

HINGED (BLIND) DOOR:

700/750/800/900 x 2100 mm

SLIDING DOOR:

700/800/900/1000 x 2100 mm

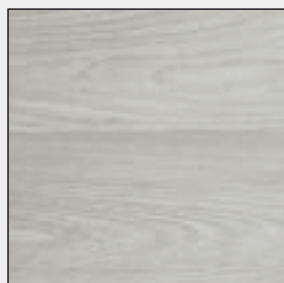

Lavagna cod. AC

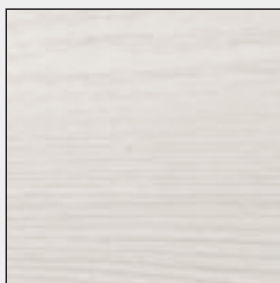

Selenite cod. AA

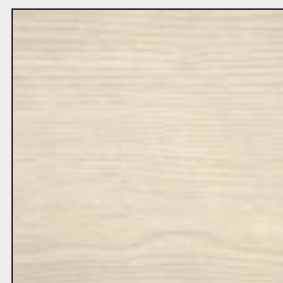

Ambra cod. AB



LAVORAZIONI

LAVORAZIONI NON NECESSARIE:

i coprifili montanti non necessitano di lavorazioni di sbancamento, in quanto già eseguite in azienda.

LAVORAZIONI NECESSARIE:

fresata da effettuare in fase di montaggio per rendere dx o sx la porta (vedi disegno sotto per fresata)

PROCESSINGS

UNNECESSARY PROCESSINGS:

horizontal jambs don't need additional frame workings, they have been already done in our company.

NECESSARY PROCESSINGS:

mill to realize while assembling the door left or right (see below mill's drawing).

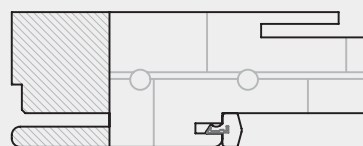
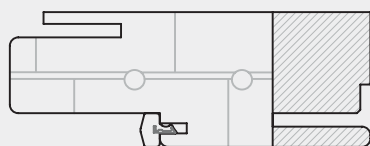
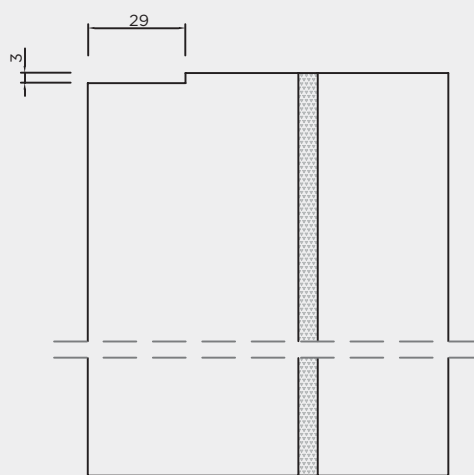
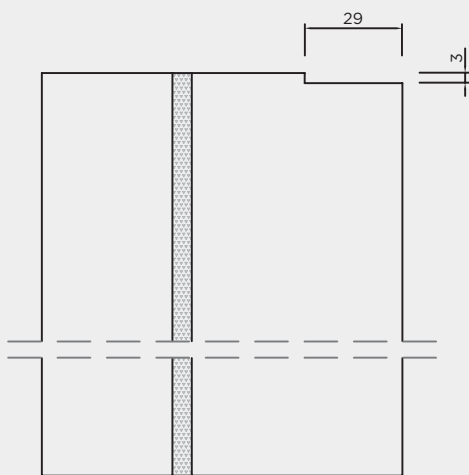









MANIGLIA DUBLIN

HANDLE DUBLIN

SERRATURA MAGNETICA

Chiusura sempre dolce e silenziosa.
La serratura magnetica di serie rende
piacevole e ovattata la chiusura,
con un sistema di regolazione
semplice e flessibile.

MAGNETICK LOCK

*Gentle and silent closing.
Stock lock makes closing pleasant
and muffled, with also a simple
and flexible regulation system*





PERNO STABILIZZATORE

Grazie all'applicazione di un perno centrale si ha la garanzia di stabilità nel tempo

STABILIZING LINCHPIN

Thanks to the central linchpin, we give the guarantee of better stability during times.

CERNIERE

Cerniere a scomparsa regolabili in 3D

HINGES

Hidden hinges, 3D adjustable



R'EVO BATTENTI

HINGED BLIND DOOR

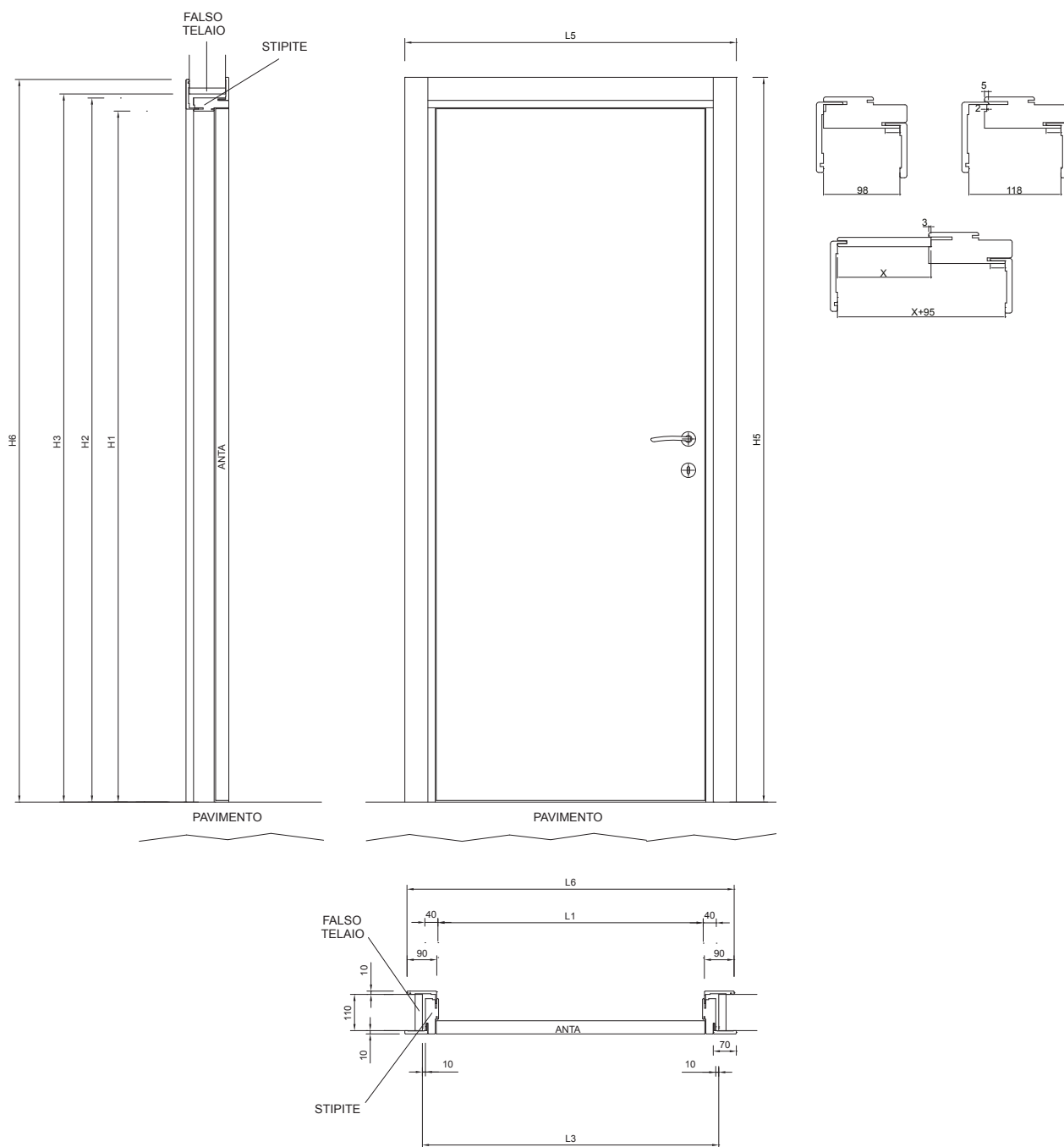

MISURE PORTA BATTENTE | HINGED BLIND DOOR SIZE

| L1 | H1 | L2 | H2 | L3 | H3 | L5 | H5 | L6 | H6 |
|-----|------|-----|------|------|------|------|------|------|------|
| 700 | 2100 | 780 | 2140 | 800 | 2150 | 907 | 2201 | 894 | 2195 |
| 750 | 2100 | 830 | 2140 | 850 | 2150 | 957 | 2201 | 944 | 2195 |
| 800 | 2100 | 880 | 2140 | 900 | 2150 | 1007 | 2201 | 994 | 2195 |
| 900 | 2100 | 980 | 2140 | 1000 | 2150 | 1107 | 2201 | 1094 | 2195 |

L1
Larghezza di passaggio
Inside width

H1
Altezza di passaggio
Headroom

L2
Larghezza esterno cassa
Width to outer edge frame

H2
Altezza esterno cassa
Height to upper edge of frame

L6
Larghezza ingombro massimo esterno
Maximum width hole-external

L3
Larghezza falso telaio
Subframe width

H3
Altezza falso telaio
Subframe height

L5
Larghezza ingombro massimo
Maximum width hole

H5
Altezza ingombro massimo
Maximum height hole

H6
Altezza ingombro massimo esterno
Maximum height hole-external

R'EVO SCORREVOLI

SLIDING DOOR

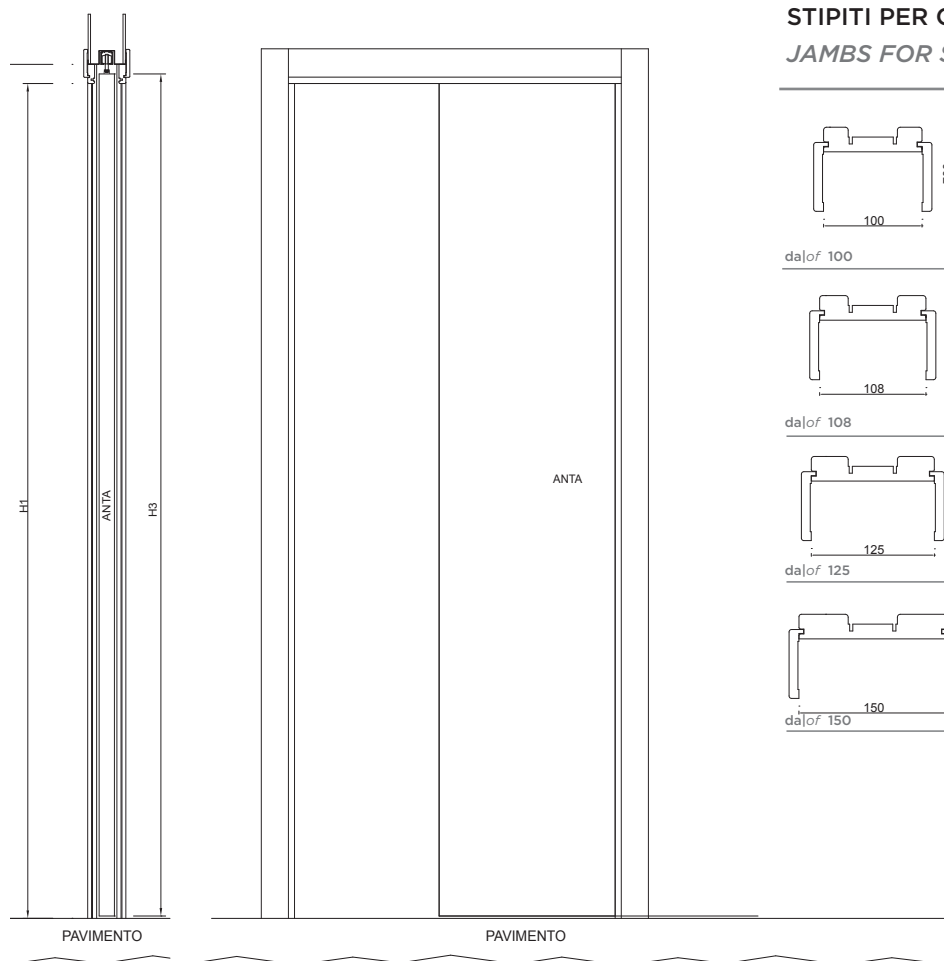

STIPITI PER CONTROTELAIO JAMBS FOR SUBFRAME

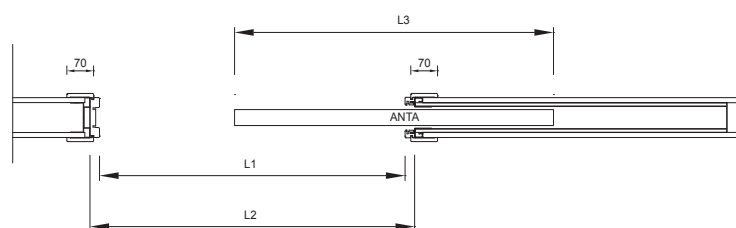
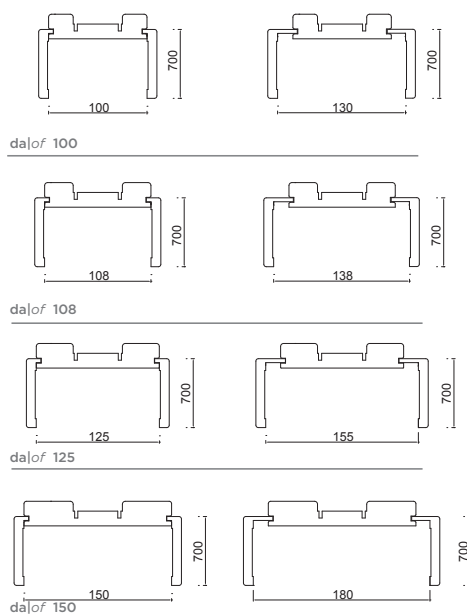

MISURE PORTA SCORREVOLE | SLIDING DOOR SIZE

| L1 | H1 | L2 | H2 | L3 | H3 | L5 | H5 |
|------|------|------|------|------|------|------|------|
| 700 | 2100 | 750 | 2150 | 735 | 2110 | 871 | 2179 |
| 800 | 2100 | 850 | 2150 | 835 | 2110 | 971 | 2179 |
| 900 | 2100 | 950 | 2150 | 935 | 2110 | 1071 | 2179 |
| 1000 | 2100 | 1050 | 2150 | 1035 | 2110 | 1171 | 2179 |

L1
Larghezza di passaggio
Inside width

H1
Altezza di passaggio
Headroom

L2
Larghezza esterno cassa
Width to outer edge frame

H2
Altezza esterno cassa
Height to upper edge of frame

L3
Larghezza falso telaio
Subframe width

H3
Altezza falso telaio
Subframe height

L5
Larghezza ingombro massimo
Maximum width hole

H5
Altezza ingombro massimo
Maximum height's hole

QUANTITÀ ORDINABILI

Minimo 12 pezzi per porta completa (ante + stipiti + coprifili + ferramenta / senza maniglia) - 1 solo colore e varie larghezze.

ACCESSORI

Fascia allargatore
(200 x 2200 x 12 mm)
lotto min. ordinabile 5pz e multipli

Battiscopa
(80 x 10 x 2250 mm)
lotto min. ordinabile 10 aste e multipli

Maniglia
lotto min. ordinabile min. 1 pz

Pannello per blindato
(90x2200x6 mm)
lotto min. ordinabile 1 pz

Ferma pannello per blindato
lotto min. ordinabile 3 pz

Fermavetro
lotto min. ordinabile 10 pz e multipli

SORTABLE QUANTITY

Minimum 12 pieces for a full door (panel + jambs + architraves + Hardware/without handle). Available in 1 color with different widths.

ACCESSORIES

*Enlargement
(200 x 2200 x 12 mm)
minimum 5 pieces and multiples*

*Skirting
(80 x 10 x 2250 mm)
minimum 10 beams and multiples*

*Handle
minimum 1 piece*

*Panel for security door
(90x2200x6 mm)
minimum 1 piece*

*Stoppers for panel for security door
minimum 3 pieces*

*Glass stopper
minimum 10 pieces and multiples*